



ONline Ethernet 24-Port 10BASE-T Module Installation Guide

Document Number 17-00232-3
Printed February 1996

Model Number: 5124M-TPCL
5124M-TP

3Com Corporation
118 Turnpike Road
Southborough, MA 01772-1886
U.S.A.
(508) 460-8900
FAX (508) 460-8950

Federal Communications Commission Notice

This equipment has been tested and found to comply with the limits for a Class A digital device, pursuant to Part 15 of the FCC Rules. These limits are designed to provide reasonable protection against harmful interference when the equipment is operated in a commercial environment. This equipment generates, uses, and can radiate radio frequency energy and, if not installed and used in accordance with the instruction manual, may cause harmful interference to radio communications. Operation of this equipment in a residential area is likely to cause harmful interference, in which case you must correct the interference at your own expense.

Canadian Emissions Requirements

Cet appareil numérique respecte les limites de bruits radioélectriques applicables aux appareils numériques de Classe A prescrites dans la norme sur la matériel brouilleur: "Appareils Numériques", NMB-003 édictée par le Ministère des Communications.

This digital apparatus does not exceed the Class A limits for radio noise emissions from digital apparatus as set out in the interference-causing equipment standard entitled "Digital Apparatus", ICES-003 of the Department of Communications.

VDE Class B Compliance

Hiermit wird bescheinigt, dass der 5124M-TPCL in Übereinstimmung mit den Bestimmungen der Vfg 243/1991 funktentstört ist.

Der Deutschen Bundespost wurde das Inverkehrbringen dieses Gerätes angezeigt und die Berechtigung zur Überprüfung der Serie auf Einhaltung der Bestimmungen eingeräumt.

Einhaltung mit betreffenden Bestimmungen kommt darauf an, dass geschirmte Ausführungen gebraucht werden. Für die Beschaffung richtiger Ausführungen ist der Betreiber verantwortlich.

This is to certify that the 5124M-TPCL is shielded against radio interference in accordance with the provisions of Vfg 243/1991.

The German Postal Services have been advised that this equipment is being placed on the market and that they have been given the right to inspect the series for compliance with regulations.

Compliance with applicable regulations depends on the use of shielded cables. The user is responsible for procuring the appropriate cables.

EN55022/CISPR22 Compliance

This equipment conforms to the Class A emissions limits for a digital device as defined by EN55022 (CISPR22).

VCCI Class 1 Compliance

この装置は、第一種電波装置（電工業規格において定められるべき情報装置）で電工業地域での電波障害防止を目的とした電波障害低減対策（電波障害低減会（VCCI））標準に適合してあります。
従って、住宅地域またはその他の隣接した地域で使用する上、ラジオ、テレビジョン受信機等に電波障害を与えることがあります。
取扱説明書に準って正しい取り扱いをして下さい。

This equipment is in the 1st Class category (information equipment to be used in commercial or industrial areas) and conforms to the standards set by the Voluntary Control Council for Interference by Information Technology Equipment aimed at preventing radio interference in commercial or industrial areas.

Consequently, when the equipment is used in a residential area or in an adjacent area, radio interference may be caused to radio and TV receivers, and so on.

Read the instructions for correct handling.

UK General Approval Statement

The ONcore Switching Hub, ONline System Concentrator, and ONsemble StackSystem Hub are manufactured to the International Safety Standard EN 60950 and are approved in the UK under the General Approval Number NS/G/12345/J/100003 for indirect connection to the public telecommunication network.

Disclaimer

The information in this document is subject to change without notice and should not be construed as a commitment by 3Com Corporation. 3Com Corporation assumes no responsibility for any errors that may appear in this document.

Copyright Statement

© 1996, by 3Com Corporation. Printed in U.S.A. All rights reserved. 3Com is a registered trademark of 3Com Corporation. ONcore is a registered trademark of 3Com Corporation. The information contained herein is the exclusive and confidential property of 3Com Corporation. No part of this manual may be disclosed or reproduced in whole or in part without permission from 3Com Corporation.

Trademarks

Because of the nature of this material, numerous hardware and software products are mentioned by name. In most, if not all cases, these product names are claimed as trademarks by the companies that manufacture the products. It is not our intent to claim these names or trademarks as our own.

Artel, Chipcom, Ethermodem, Galactica, ONcore, ORnet, StarBridge, and TriChannel are registered trademarks of 3Com Corporation.

Chipcom OpenHub, G-Man, LANsentry, MultiProbe, ONdemand, ONline, ONsemble, PowerRing, SL2000, SL3000, SL4000, StackJack, StackSystem, and SwitchCentral are trademarks of 3Com Corporation.

The Chipcom Multichannel Architecture Communications System is registered under U.S. Patent Number 5,301,303.

XNS is a trademark of Xerox Corporation.

DEC, DECnet, the Digital logo, DELNI, POLYCENTER, VAX, VT100, and VT220 are trademarks of Digital Equipment Corporation.

IBM is a registered trademark of International Business Machines. NetView is a trademark of International Business Machines.

3ComFacts, Ask 3Com, CardFacts, NetFacts, and CardBoard are service marks of 3Com Corporation.

3Com, LANplex, BoundaryRouting, LanScanner, LinkBuilder, NETBuilder, NETBuilderII, ParallelTasking, ViewBuilder, EtherDisk, Ether\Link, EtherLink Plus, EtherLink II, TokenLink, TokenLink Plus, and TokenDisk are registered trademarks of 3Com Corporation.

3ComLaser Library, 3TECH, CacheCard, FDDILink, FMS, NetProbe, SmartAgent, Star-Tek, and Transcend are trademarks of 3Com Corporation.

CompuServe is a registered trademark of CompuServe, Inc.

3Com registered trademarks are registered in the United States, and may or may not be registered in other countries. Other brand and product names may be registered trademarks or trademarks of their respective holders.

Restricted Rights

Use, duplication, or disclosure by the Government is subject to restrictions as set forth in subparagraph (c)(1)(ii) of the Rights in Technical Data and Computer Software clause at DFARS 252.227-7013.

Printed on recycled paper.

Contents

How to Use This Guide

Audience	xiii
Structure of This Guide	xiv
Document Conventions	xv
Related Documents	xvi
3Com Documents	xvii
Reference Documents	xvii

Chapter 1 – Introduction

Ethernet 24-Port 10BASE-T Module Description	1-1
Module Features	1-2
Bank Switching Capability	1-3
Model Number 5124M-TPCL Features	1-3
Model Number 5124M-TP Features	1-4
Theory of Operation	1-4

Chapter 2 – Designing and Expanding the Network

Understanding the General Rules	2-2
Rules for Configuring a Network	2-2
LAN Equivalence	2-6
Choosing a Network Backbone Cabling Structure	2-7
Building a Network (Star Configuration)	2-8
Building a Network (Serial Configuration)	2-9
24-Port Module Configurations	2-10
Fiber Backbone, 10BASE-T To-The-Desk	2-10
10BASE-T Backbone, 10BASE-T To-The-Desk	2-12
Using Patch Panels	2-14
Establishing Fault-Tolerant Configurations	2-14
Setting Port Redundancy	2-15
Configuring Ports for Fault Tolerance	2-15

Setting Backbone Redundancy	2-15
Redundant Twisted Pair Backbone	2-16

Chapter 3 – Installing and Operating the Module

Precautionary Procedures	3-2
Quick Installation	3-2
Unpacking Procedures	3-4
Setting the DIP Switches	3-4
DIP Switch Overview	3-5
DIP Switch Description	3-7
Installing the Module	3-10
Using 90° Cable Connectors	3-13
Installing the Cable Tie-Wrap Kit	3-13
Securing 90° Cables to the Module	3-15
Configuration in a Managed Environment	3-17
If Management is Not Available	3-18
Before Configuring the Module	3-19
Enabling Ports	3-19
Enabling Port Redundancy	3-19
Enabling Link Integrity	3-20
Selecting a Network	3-20
Enabling Remote Diagnostics Mode	3-21
Setting the Autopartition Threshold Value	3-22
Saving Module Configurations	3-23
Showing Module Configurations	3-23
Show Module	3-24
Show Port	3-25
Gathering Network Statistics	3-27
Selecting the Per-Port Counters Connector	3-28
Monitoring the Front Panel	3-29
Verifying LED and Network Assignments	3-32
Using the LED Check Button	3-32

Chapter 4 – Troubleshooting

Troubleshooting Using the Port Status and Port Activity LEDs	4-2
Troubleshooting Using the Port Status LEDs	4-2
Troubleshooting Using the Port Activity LEDs	4-4
Technical Assistance	4-4

Appendix A – Specifications

General Specifications	A-2
Power Specifications	A-3
Environmental Specifications	A-4
Mechanical Specifications	A-5
Twisted Pair Cable and Connector Specifications	A-5
Twisted Pair Cable Specifications	A-6
Twisted Pair Connector Specifications	A-7
RJ-45 Connector Pinouts	A-7
50-Pin Connector Pinouts	A-8
Connecting Twisted Pair Cables	A-12

Appendix B – Technical Support

On-line Technical Support	B-1
Email Technical Support	B-2
World Wide Web Site	B-2
Support from Your Network Supplier	B-2
Support from 3Com	B-3
Returning Products for Repair	B-4
Accessing the 3Com MIB	B-4
3Com Technical Publications	B-5

Index

Figures

Figure 1-1.	Typical 24-Port Module Configuration	1-5
Figure 2-1.	Star-Wiring Configuration	2-8
Figure 2-2.	Serial Configuration	2-9
Figure 2-3.	Sample Configuration Distance Calculation Using 24-Port Modules	2-11
Figure 2-4.	Unshielded Twisted Pair Network Using 24-Port Modules .	2-13
Figure 2-5.	Redundant Twisted Pair Configuration Using 24-Port Modules	2-16
Figure 3-1.	Model 5124M-TPCL and Model 5124M-TP DIP Switch Location	3-6
Figure 3-2.	Installing a 24-Port Module (Model Number 5124M-TPCL)	3-11
Figure 3-3.	24-Port Module Cable Connection (Model Number 5124M-TPCL)	3-12
Figure 3-4.	Attaching the Tie-Wrap Bracket to the Module	3-14
Figure 3-5.	Attaching Cables With 90° Connectors (Model Number 5124M-TPCL)	3-15
Figure 3-6.	Attaching Cables With 90° Connectors	3-16
Figure 3-7.	24-Port Module Faceplate and ONline System Concentrator (Model Number 5124M-TPCL)	3-29
Figure 3-8.	24-Port Module Faceplate and ONline System Concentrator (Model Number 5124M-TP)	3-30
Figure A-1.	24-Port Module RJ-45 Connector Pinouts	A-8
Figure A-2.	50-Pin Male and Female Connectors	A-9

Tables

Table 2-1.	Seven Basic Network Rules	2-3
Table 2-2.	LAN Product Equivalent Distances	2-6
Table 3-1.	Procedures for Completing Installation	3-2
Table 3-2.	DIP Switch Settings	3-8
Table 3-3.	Channel (Network) Select DIP Switch Settings	3-9
Table 3-4.	24-Port Module LED Interpretations.	3-31
Table 3-5.	Network Check Codes.	3-33
Table 4-1.	Troubleshooting Using the Port Status LEDs.	4-2
Table 4-2.	Troubleshooting Using the Port Activity LEDs.	4-4
Table A-1.	24-Port Module General Specifications.	A-2
Table A-2.	24-Port Module Power Specifications.	A-3
Table A-3.	24-Port Module Fuse Specifications	A-4
Table A-4.	24-Port Module Environmental Specifications.	A-4
Table A-5.	24-Port Module Mechanical Specifications	A-5
Table A-6.	IBM Twisted Pair Cable Specifications	A-6
Table A-7.	50-Pin Cable Pinouts and Port Assignments	A-10

How to Use This Guide

This guide tells you how to install and operate the 3Com ONline™ Ethernet 24-Port 10BASE-T Module for the ONline System Concentrator. It also includes information on monitoring this module using an ONline network management module. An appendix explains cabling guidelines and options for this module.

Audience

This guide is intended for the following people at your site:

- Network manager or administrator
- Hardware installer

Structure of This Guide

This guide contains the following chapters:

Chapter 1, Introduction – Introduces the functions and features of the ONline Ethernet 24-Port 10BASE-T Module.

Chapter 2, Designing and Expanding the Network – Shows possible network configurations using the ONline System Concentrator and the ONline Ethernet 24-Port Module.

Chapter 3, Installing and Operating the Module – Provides illustrated procedures for installing the 24-Port Module into the ONline System Concentrator. Also shows front panel LEDs and dip switches on the module and describes network management commands.

Chapter 4, Troubleshooting – Provides help in isolating and correcting problems that may arise when installing or operating this module.

Appendix A, Specifications – Provides electrical, environmental, and mechanical specifications, plus information on 50-pin Telco-type connectors, RJ-45 connectors, and twisted pair cables.





Appendix B, Technical Support – Lists the various methods for contacting the 3Com technical support organization and for accessing other product support services.

Index

Document Conventions

The following document conventions are used in this manual:

Convention	Indicates	Example
Courier text	User input	In the Agent Information Form, enter <code>MIS</code> in the New Contact field.
	System output	After pressing the Apply button, the system displays the message <code>Transmitting data.</code>
Bold command string	Path names	Before you begin, read the <code>readme.txt</code> file located in <code>/usr/snm/agents</code> .
Italic text in braces	User-substituted identifiers	Use the following command to show port details: <code>SHOW PORT {slot.all} VERBOSE</code>
Capitalized text in plain brackets	Keyboard entry by the user	Type your password and press <code>[ENTER]</code> .
Italics	Text emphasis, document titles	Ensure that you press the Apply button <i>after</i> you add the new search parameters.

Convention	Indicates	Example
Note:	A Note . The information is important	Note: Use STP lobe cables for your system.
 Caution:	A Caution . A condition may damage software or hardware	 Caution: Do not put your installation diskettes on a magnetic surface. This may damage the diskettes.
 Warning:	A Warning . A condition may threaten personal safety	 Warning: Wear eye protection when performing these maintenance procedures.

Related Documents

This section provides information on supporting documentation, including:

- ❑ 3Com Documents
- ❑ Reference Documents

3Com Documents

The following documents provide additional information on 3Com products:

17-Slot ONline System Concentrator Installation and Operation Guide – Explains how to install, operate, and manage the 3Com ONline 17-Slot System Concentrator (Models 5017C-LS and 5017C with load sharing).

6-Slot ONline System Concentrator Installation and Operation Guide – Explains how to install, operate, and manage the 3Com ONline 6-Slot System Concentrator.

ONline Ethernet Management Module Installation and Operation Guide – Describes how to install the ONline Ethernet Management Module in the ONline System Concentrator and explains the LEDs on the module faceplate. This guide also provides instructions for connecting a terminal to the module and describes the management commands necessary to perform management tasks on the concentrator and on remote devices.

ONline Management Commands Guide – Provides an alphabetized reference resource describing all ONline management commands.

For a complete list of 3Com documents, contact your 3Com representative.

Reference Documents

The following documents supply related background information:

Case, J., Fedor, M., Scoffstall, M., and J. Davin, *The Simple Network Management Protocol*, RFC 1157, University of Tennessee at Knoxville, Performance Systems International and the MIT Laboratory for Computer Science, May 1990.

Rose, M., and K. McCloghrie, *Structure and Identification of Management Information for TCP/IP-based Internets*, RFC 1155, Performance Systems International and Hughes LAN Systems, May 1990.

1

Introduction

This chapter introduces you to the 3Com ONline™ Ethernet 24-Port 10BASE-T Modules (Model Numbers 5124M-TPCL and 5124M-TP). The modules are referenced throughout this guide as the 24-Port Module.

You can install both versions of the 24-Port Module in all 3Com ONline System Concentrator and ONcore® Switching Hub models.

This chapter contains the following sections:

- ❑ Ethernet 24-Port 10BASE-T Module Description
- ❑ Theory of Operation

Ethernet 24-Port 10BASE-T Module Description

This section describes:

- ❑ Module Features
- ❑ Model Number 5124M-TPCL Features
- ❑ Model Number 5124M-TP Features

The ONline Ethernet 24-Port Module is an IEEE 802.3 repeater module that complies with the 10BASE-T standard. It connects up to 24 devices (PCs, terminals, printers, modems) to the ONline System Concentrator.

The 24-Port Module (Model Number 5124M-TPCL and Model Number 5124M-TP) is a bank switching module. *Bank switching* is the assignment of a group of 12 consecutive ports to a single network, or to an isolated network.

Note: You cannot assign individual ports on the 5124M-TPCL and the 5124M-TP modules to different networks.

Module Features

The ONline Ethernet 24-Port 10BASE-T Module:

- ❑ Is an IEEE 802.3 repeater module that complies with the 10BASE-T standard.
- ❑ Connects up to 24 devices (PCs, terminals, printers, modems) to the 3Com ONline System Concentrator or ONcore Switching Hub.
- ❑ Provides high port density at a low cost per port.
- ❑ Supports up to 100 meters on 10BASE-T-compliant unshielded twisted pair (UTP) or shielded twisted pair (STP) wiring.
- ❑ Features “hot swap” capability so that you can install or remove the module without having to power down the concentrator.
- ❑ Provides bank-switching capability.
- ❑ Provides a user-selectable autopartition threshold for flexibility in dealing with collision-related network slowdowns.
- ❑ Allows you to disable Link Integrity so you can connect to equipment that does not conform to the 10BASE-T standard.

- ❑ Is designed with all ports internally crossed over, as required by the 10BASE-T standard. This enables you to connect the 24-Port Module to a 10BASE-T transceiver without using an external crossover adapter.

Bank Switching Capability

Bank switching is the assignment of a group of twelve consecutive ports to a single network, or to an isolated network.

In an unmanaged concentrator you can use DIP switches to:

- ❑ Assign *all* module ports to an Ethernet network or to an isolated network
- ❑ Assign port groups 1 through 12 or 13 through 24 to different Ethernet or isolated networks

In a managed concentrator you can use network management commands to assign the following port “groups” to any of three backplane networks, or to either of two isolated networks:

- ❑ Ports 1 through 12
- ❑ Ports 13 through 24
- ❑ All ports on the module

Model Number 5124M-TPCL Features

Model Number 5124M-TPCL permits you to connect groups of 12 consecutive 10BASE-T-compliant module ports using:

- ❑ Two 50-pin Telco connectors (one connector attached to 12 ports)
- ❑ Two 25-pair 10BASE-T cables *or* two 12-leg “hydra” cables (one cable per 12 ports)

Model Number 5124M-TP Features

Model Number 5124M-TP permits you to connect individual 10BASE-T-compliant ports using 24 RJ-45 connectors (one connector per port). The RJ-45 connectors provide direct connections to 10BASE-T cables (one cable per connected port).

Theory of Operation

ONline Ethernet 24-Port 10BASE-T Modules incorporate repeaters and twisted pair transceivers that receive and restore amplitude to incoming signals. 24-Port Module repeaters restore phase and frequency.

Repeated signals:

- ❑ Synchronize to the system clock
- ❑ Enter on the TriChannel® backplane of the ONline System Concentrator.

Outgoing signals from the TriChannel backplane are:

- ❑ Sent directly to transceivers
- ❑ Transmitted to twisted pair link segments by the transceivers

Figure 1-1 shows a 24-Port Module (Model Number 5124M-TPCL) connected to nodes by means of bundled 25-pair or 12-leg hydra cables and patch panels.

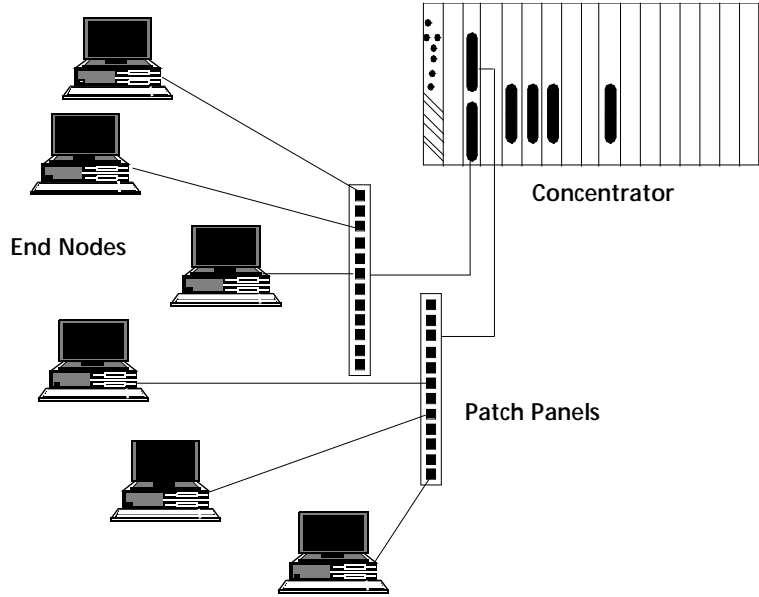

Figure 1-1. Typical 24-Port Module Configuration

2 *Designing and Expanding the Network*

This chapter contains configuration information to help you design your network. It describes how to configure networks using the ONline System Concentrator and ONline Ethernet 24-Port 10BASE-T Modules. It also provides examples of network cabling structures and Ethernet network cabling solutions.

This chapter contains the following sections:

- ❑ Understanding the General Rules
- ❑ Choosing a Network Backbone Cabling Structure
- ❑ 24-Port Module Configurations
- ❑ Using Patch Panels
- ❑ Establishing Fault-Tolerant Configurations

Note: To ensure proper operation of your network, install all equipment using only approved cables. Refer to Appendix A for information on cable requirements.

Understanding the General Rules

This section describes general rules for configuring an Ethernet network using fiber as the backbone medium. It also provides rules to ensure that your network configuration conforms to distance limitations imposed by Ethernet and networking equipment. Use these guidelines for building your network.

Refer to the sections that follow for specific rules for:

- ❑ Determining maximum 24-Port Module fiber link distances
- ❑ Connecting various horizontal media types (10BASE-FB, twisted pair) to a 10BASE-FB backbone
- ❑ Examples of recommended fault-tolerant configurations

This section describes:

- ❑ Rules for Configuring a Network
- ❑ Calculating Equivalent Fiber Distances

Rules for Configuring a Network

This section outlines seven basic network rules and 3Com recommendations for building an Ethernet network.

For more hardware-specific information on the 24-Port Module, refer to Appendix A.

Table 2-1. Seven Basic Network Rules

Rule	Definition	Recommendations/Notes
1	If possible, use 10BASE-FB as the backbone medium.	Use 62.5 micron cable to conform with the IEEE 10BASE-F and upcoming ANSI FDDI standards.
		Use ST-type connectors.
2	Wire the backbone in a star topology to isolate faults.	Make sure to lay extra fiber cables. The extra cost is small and you will find you need them as your network grows.
		The star topology conforms to FDDI wiring as well -- just make sure to run at least two fiber strands to every backbone connection.
3	The maximum Fiber Ethernet network diameter is 4200 meters of fiber cable.	<p>The 4200 meters is the maximum distance between any two transceivers on the network.</p> <p>The 4200 meters <i>does not include</i> the transceiver cable (that is, drop or patch cable) that connects a device with an external transceiver. Transceiver cables can extend up to 50 meters. Thus, total network diameter can be as much as 4300 meters (4200 m + 2 * 50 m) between any two nodes.</p>

Table 2-1. Seven Basic Network Rules (Continued)

Rule	Definition	Recommendations/Notes
4	Certain LAN devices on the network shrink the maximum Fiber Ethernet network diameter to less than 4200 meters.	Many LAN products delay the signal that goes through them. This is known as <i>equivalent distance</i> . Every microsecond delay reduces the maximum link distance. In fact, every microsecond delay shrinks the network diameter by approximately 200 meters of fiber cable. Table 2-2 lists the Equivalent Distances for other 3Com products.
5	Assume that one meter of coaxial or twisted pair is equal to one meter of fiber cable.	This is a conservative rule. For example, the actual equivalence is about 1.1 meters of coaxial for every meter of fiber. For simplicity, assume one meter.

Table 2-1. Seven Basic Network Rules (Continued)

Rule	Definition	Recommendations/Notes
6	The fiber link distances must not exceed the limits imposed by the optical power budget.	<p>In general, on 62.5 micron cable, you can go up to 4000 meters point-to-point using the ONcore or ONline Fiber Modules. If you have poor quality cable or cross many patch panels, you may have to sacrifice some distance.</p> <hr/> <p>Some older Ethernet fiber optic products are less powerful than ONcore Fiber Module optics. So when connecting to these products, remember that the least powerful device determines the maximum point-to-point distance.</p>
7	When in doubt, use a bridge.	If you are not certain if you have exceeded allowable network distances, use a bridge to extend the network.

LAN Equivalence

LAN equivalence is the sum of both the incoming and outgoing module port signals. Different modules, however, have different equivalent distances. Table 2-2 lists the LAN product equivalent distances.

Table 2-2. LAN Product Equivalent Distances

LAN Product	Equivalent Distance (meters)
ONcore Ethernet 10-Port 10BASE-FB Module	190
Incoming signal to fiber port	140
Outgoing signal from fiber port	50
ONcore Ethernet 10BASE-T Module	585
Incoming signal to TP port	420
Outgoing signal from TP port	165
ONline Ethernet 10BASE-T Modules	585
Incoming signal to TP port	420
Outgoing signal from TP port	165
ONline Ethernet Fiber or 10BASE-FB Modules	190
Incoming signal to fiber port	140
Outgoing signal from fiber port	50
ONline Ethernet FOIRL Module	560
Incoming signal to fiber port	330
Outgoing signal from fiber port	230
ONline Ethernet Transceiver Module	0
ORnet Star Coupler (8 or 14 port) 26	180

Table 2-2. LAN Product Equivalent Distances (Continued)

LAN Product	Equivalent Distance (meters)
ONline Ethernet BNC Module	900
Incoming signal to BNC port	450
Outgoing signal from BNC port	450
ONline Ethernet Repeater Module	800
Incoming signal to AUI port	600
Outgoing signal from AUI port	200
IEEE Repeater	800

Choosing a Network Backbone Cabling Structure

Because of fiber's long-distance capabilities and immunity to noise, 3Com strongly recommends using fiber as the backbone.

This section describes:

- Building a Network (Star Configuration)
- Building a Network (Serial Configuration)

You can implement either of these configuration topologies when connecting your network backbone using 10BASE-FB modules installed in an ONline System Concentrator.

Building a Network (Star Configuration)

Wire your network in a star configuration using an ONline System Concentrator as the central point in the network. Wiring in a star configuration provides two major benefits:

- ❑ Faults in the cable plant affect only a piece of the network.
- ❑ You can easily expand the size of your network.

Figure 2-1 shows 10BASE-T and 10BASE-FB modules installed in a star-wired network.

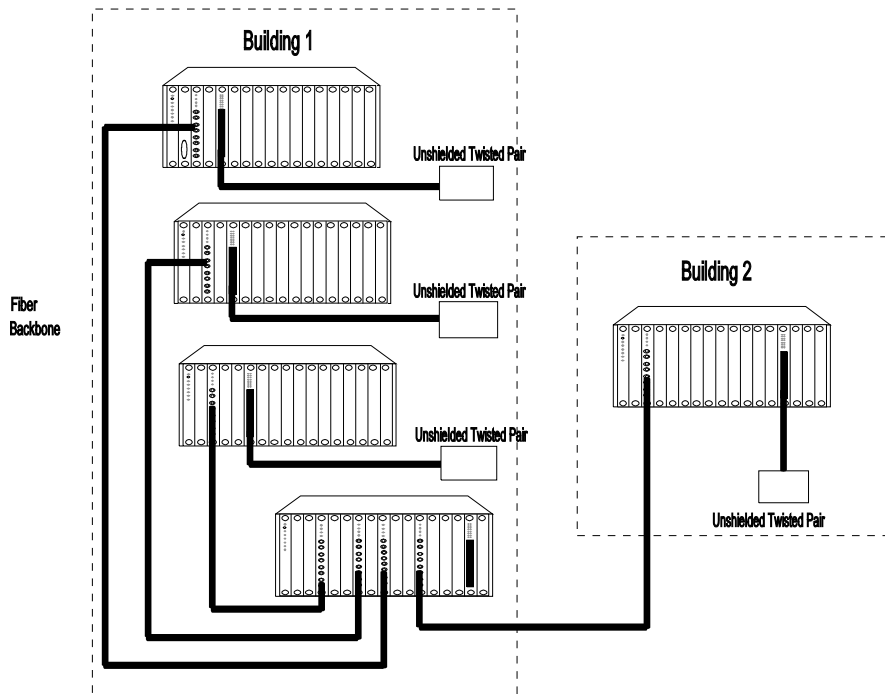

Figure 2-1. Star-Wiring Configuration

Building a Network (Serial Configuration)

Use a serial configuration for smaller diameter networks that are not expected to grow. Serial configurations reduce the overall network diameter by 190 meters for each concentrator in any path.

Figure 2-2 shows 10BASE-FB modules installed in a network using a serial configuration.

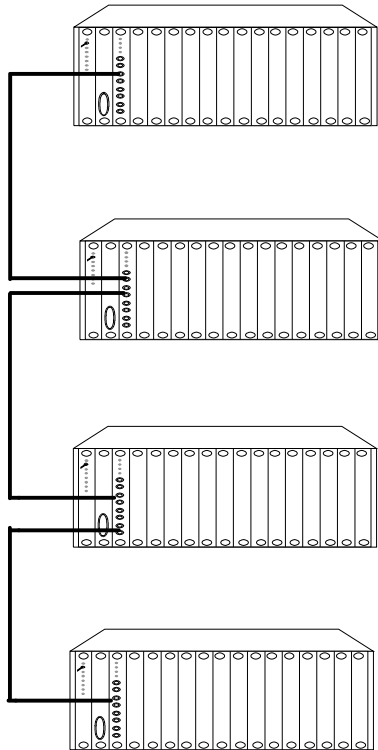

Figure 2-2. Serial Configuration

24-Port Module Configurations

This section describes how to define total network size based on the limits of IEEE 802.3 collision detection. This section also describes how to construct a network consisting of a Fiber Backbone and 10BASE-T unshielded twisted pair connections to-the-desk.

This section describes:

- ❑ Fiber Backbone, 10BASE-T To-The-Desk
- ❑ 10BASE-T Backbone, 10BASE-T To-The-Desk

Fiber Backbone, 10BASE-T To-The-Desk

Be aware of the following additional rules for configuring a network:

- ❑ The four-repeater rule in Ethernet limits the number of 10BASE-T modules between any two transceivers. The path from the TP port to the backplane counts as 1/2 of a repeater and the path from the backplane to the TP port counts as 1/2 of a repeater. You must add a bridge if the path from one transceiver to another exceeds the four-repeater rule.
- ❑ The equivalent fiber distance for 10BASE-T modules is defined as follows:
 - 420 meters for signals that externally enter a 10BASE-T module port
 - 165 meters for signals that internally enter a 10BASE-T module through the ONline concentrator backplane

For each pair of 10BASE-T modules that a signal goes through, there is an equivalent fiber distance of 585 meters (420 m + 165 m = 585 m). In addition, if a signal makes a roundtrip through a 10BASE-T Module (that is, enters a 10BASE-T port externally and exits through another port on the same 10BASE-T module), that counts as 585 meters of equivalent fiber distance, and as a full repeater.

Example: Sample Configuration Distance Calculation

Use the following example to determine if the 10BASE-T transceivers in Figure 2-3 are within legal Ethernet limits. Identify the two transceivers that are likely to be the greatest fiber equivalent distance apart. In Figure 2-3, they are 10BASE-T transceivers A and B.

Figure 2-3 shows 24-Port Modules installed in each of three concentrators.

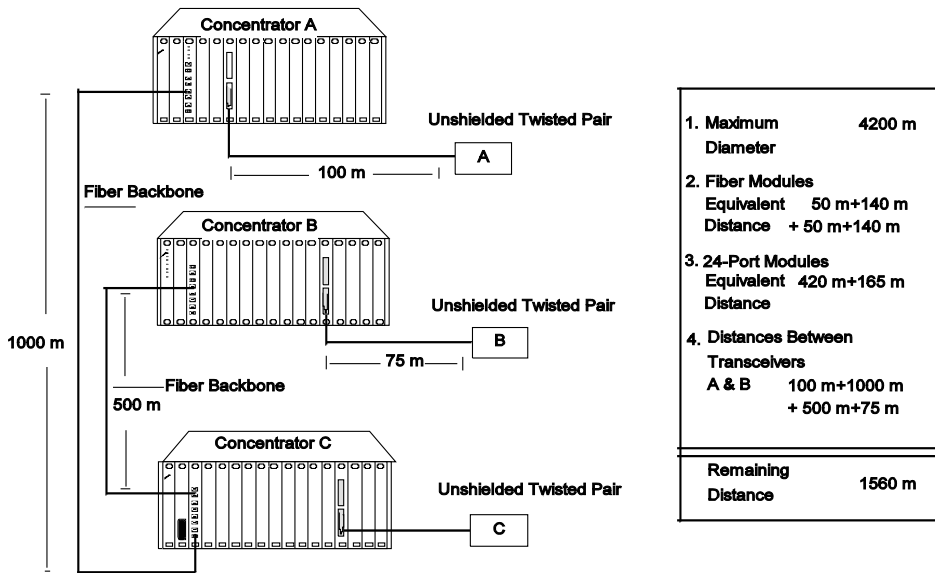

Figure 2-3. Sample Configuration Distance Calculation Using 24-Port Modules

To determine if your network configuration is legal:

1. Use 4200 m as the maximum network diameter for a pure fiber network as defined by the 802.3 specification.

2. Calculate the equivalent distances for each concentrator, and subtract the total from 4200.
3. Subtract all cable lengths between the two transceivers and if the result is greater than zero, the configuration is within legal Ethernet limits.

For the configuration shown in Figure 2-3 to work, ensure the equivalent fiber distance between Transceiver A and Transceiver B is less than 4200 meters.

As shown in the calculation, there are still 1510 meters left for expansion in this configuration. Therefore, this configuration is legal.

10BASE-T Backbone, 10BASE-T To-The-Desk

In constructing a twisted pair backbone:

- ❑ Ensure there are no more than eight 10BASE-T modules in the path between any two transceivers (Ethernet four-repeater rule). Each 10BASE-T module counts as 1/2 of a repeater *unless* the signal goes in one port and out another port on the same module. In that case, the module counts as a full repeater.
- ❑ Add a bridge if you have more than eight 10BASE-T modules serially connected. Each bridge creates a subnetwork. Each subnetwork can have its own 4200 meter network diameter.

Figure 2-4 shows a possible unshielded twisted pair network using 24-Port Modules and 24-gauge cable.

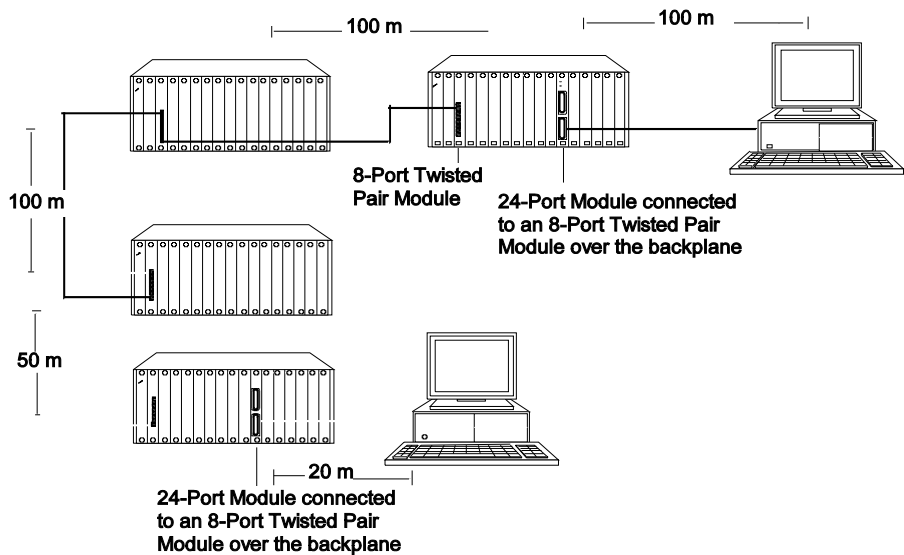

Figure 2-4. Unshielded Twisted Pair Network Using 24-Port Modules

The *equivalent fiber distance* can be calculated as follows:

Total link distance: $100\text{ m} + 100\text{ m} + 100\text{ m} + 50\text{ m} + 20\text{ m} = 370\text{ m}$

Total equivalent distance of the 24-Port Modules:

$4 * 420\text{ m} + 4 * 165\text{ m} = 2340\text{ m}$

(signal externally enters 4 Twisted Pair Modules: $4 * 420\text{ m}$)

(signal internally enters 4 Twisted Pair Modules from the backplane: $4 * 165\text{ m}$)

Note: All 3Com 10BASE-T modules (8-Port 10BASE-T Module, 50-Pin 10BASE-T Module, or the 24-Port 10BASE-T Modules) fall under these same rules.

Total equivalent distance: $370\text{ m} + 2340\text{ m} = 2710\text{ m}$

Because the total equivalent distance (2710 m) is less than 4200 meters, this configuration is legal.

Using Patch Panels

Patch panels weaken signals that pass through them, thereby reducing achievable link distances. 3Com assumes the use of one patch panel in the 100 meter link distance calculations specified in this installation guide. Each *additional* patch panel in the link reduces the 100 meter link distance by approximately 10 meters.

In Figure 2-4:

- ❑ If two patch panels were used between the top right PC and the top right concentrator, the link distance of 100 meters would have to be shortened to 90 meters.
- ❑ The link distance would have to be shortened to 90 meters because the maximum allowable link distance on 24-gauge wire using 10BASE-T signaling with two intervening patch panels is 100 meters minus approximately 10 meters.
- ❑ A patch panel installed between the bottom right PC and the bottom left concentrator would not affect the link because it is only 20 meters away.

Establishing Fault-Tolerant Configurations

You can establish fault tolerance for any port on the 24-Port Module, for selected portions of the network backbone, or for the entire network backbone.

This section describes:

- ❑ Setting Port Redundancy
- ❑ Setting Backbone Redundancy

Setting Port Redundancy

When you enable redundancy between two ports, the ports are automatically enabled. Once port redundancy is enabled:

- ❑ Port 1 is the primary link, which passes data.
- ❑ Port 2 is the redundant link, which does not pass data in either direction. However, the link is monitored for any failures (the Port Status LED indicates any problems).

Configuring Ports for Fault Tolerance

You can configure the 24-Port Module ports in one of three different ways:

- ❑ **Normal Configuration** - All ports operate as independent cable ports.
- ❑ **Flexible Redundant Configuration** - You can arbitrarily assign primary and backup ports to any pair of ports. You can configure this mode only through the advanced management commands provided with the Ethernet Management Module Version v3.0 or later.
- ❑ **Normal and Redundant Configuration** - You can enable redundancy between one set of ports and have the remaining ports operate as independent ports.

Setting Backbone Redundancy

For maximum backbone tolerance, connect both the primary and backup ports back to the central concentrator (refer to Figure 2-5). This configuration allows the backup port to automatically take over if the primary link fails.

Redundant Twisted Pair Backbone

You can implement twisted pair link redundancy between ONline System Concentrators using network management.

Figure 2-5 shows an example of a redundant configuration between concentrators using 24-Port Modules.

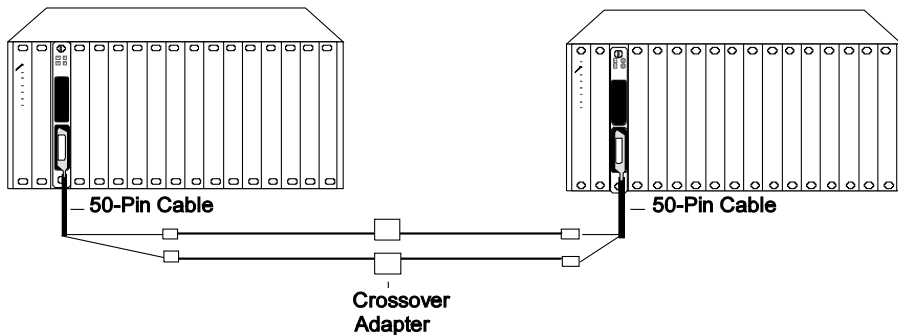

Figure 2-5. Redundant Twisted Pair Configuration Using 24-Port Modules

To set link redundancy between two 24-Port Modules (refer to Figure 2-5):

1. Connect one port on the 24-Port Module installed in the concentrator on the left to a corresponding port on the 24-Port Module installed in the concentrator on the right.
2. Connect the second port on the 24-Port Module installed in the concentrator on the left to a corresponding port on the 24-Port Module installed in the concentrator on the right.

Note: Use a crossover adapter between each link because the links are designed to be connected to station ports, *not* to other lobe ports.

3. Use the SET PORT MODE REDUNDANT network management command to specify which port is the primary link and which is the backup link.

Note: If the 24-Port Modules are powered down, and then brought back up without a 3Com network management module present, a network loop may occur. To prevent possible network failure, set the DIP switch for the backup port to disable.

Once redundancy is configured, a switchover occurs under two conditions:

- Link failure
- Port partition

The switchover occurs when the primary link fails.

A switchover *back* to the primary link happens automatically once the problem is resolved.

Refer to the appropriate network management module installation and operation guide for information on setting redundancy between 24-Port Module ports.

3 *Installing and Operating the Module*

This chapter describes installation procedures for the ONline Ethernet 24-Port 10BASE-T Modules (Model Number 5124M-TPCL and Model Number 5124M-TP).

This chapter contains the following sections:

- ❑ Precautionary Procedures
- ❑ Quick Installation
- ❑ Unpacking Procedures
- ❑ Setting the DIP Switches
- ❑ Installing the Module
- ❑ Configuration in a Managed Environment
- ❑ Saving Module Configurations
- ❑ Showing Module Configurations
- ❑ Gathering Network Statistics
- ❑ Monitoring the Front Panel
- ❑ Verifying LED and Network Assignments

Precautionary Procedures

Electrostatic discharge (ESD) can damage static-sensitive devices on circuit boards. Follow these precautions when you handle the 24-Port Module.

- ❑ Do not remove the board from its antistatic shielding bag until you are ready to inspect or install it.
- ❑ Handle the board by the faceplate only.
- ❑ Use proper grounding techniques when you install the 24-Port Module. These techniques include:
 - Using a foot strap and grounded mat or wearing a grounded static discharge wrist strap.
 - Touching the grounded rack or other source of ground just before you handle a 24-Port Module.

Quick Installation

Table 3-1 outlines the steps for installing your module. If you are familiar with installing ONline modules, you may want to use this table as a checklist. Otherwise, consult the remainder of this chapter.

Table 3-1. Procedures for Completing Installation

Step	Procedure	Section Title
1	Verify that your network complies with the basic rules for network design.	Chapter 2, Designing and Expanding the Network
2	Unpack the module.	Chapter 3, Unpacking Procedures section

Table 3-1. Procedures for Completing Installation

Step	Procedure	Section Title
3	If you do <i>not</i> have a management module installed in the concentrator, configure the DIP switch settings to your specifications.	Chapter 3, Setting the DIP Switches section
4	If you have Model Number 5124M-TPCL, insert the module into a single open slot in the concentrator and tighten the faceplate screws. If you have Model Number 5124M-TP, insert the module into two consecutive empty slots in the concentrator and tighten the faceplate screws.	Chapter 3, Installing the Module section
5	Establish connections from the 24-Port Module to devices or to a 10BASE-T transceiver using the appropriate connectors and cabling.	Chapter 3, Installing the Module section
6	If you have a management module installed in the concentrator, configure the module using the management commands.	Chapter 3, Configuring the Module section
7	Verify LED status for normal operation. Note: To correct problems, consult the troubleshooting techniques in Chapter 4.	Chapter 3, Verifying LED and Network Assignments section

Unpacking Procedures

When unpacking your 24-Port Module:

1. Verify that the 24-Port Module is the model you ordered by checking the model number listed on the side of the shipping carton (Model Number 5124M-TPCL or Model Number 5124M-TP).

Note that the product model number printed on the shipping box differs from the model number on the product. The model number on the shipping box contains the prefix '3C9'.

2. Remove the module from the shipping carton.
3. Remove the module from the antistatic shielding bag and inspect it for damage. If the module appears to be damaged, replace it in the antistatic shielding bag, return it to the shipping carton, and contact your local supplier.
4. Keep the shipping carton and antistatic shielding bag in which your module was shipped for repackaging the module for storage or shipment.
5. Record the serial number of your 24-Port Module. A log for this and other information specific to your modules is included in the *ONline System Concentrator Installation and Operation Guide*, Appendix B, Slot Usage Chart.

Setting the DIP Switches

This section describes:

- DIP Switch Overview
- DIP Switch Description

DIP Switch Overview

The 24-Port Module has a single switch located on the module. This switch contains 10 DIP switches that let you:

- ❑ Assign 12-ports on each 50-pin connector to a network (Model Number 5124M-TPCL)
- ❑ Assign 12 ports on each Double Stack RJ-45 connector to a network (Model 5124M-TP)
- ❑ Enable or disable all ports on each connector
- ❑ Establish Link Integrity for each connector (or group of 12 ports)
- ❑ Isolate all ports on one connector (or group of 12 ports)
- ❑ Isolate all ports on both connectors. This setting isolates the module from the backplane.

Note: All DIP switch settings on the 24-Port Module are ignored if an ONline management module (EMM Version v3.2 or later [for Model Number 5124M-TPCL] EMM Version v4.3 or later [for Model Number 5124M-TP]) is already installed in the concentrator. 3Com recommends that you use network management commands to configure the module instead of the DIP switches. To override management and configure the module to DIP switch settings in a managed hub, enter the SET DEVICE DIP_CONFIGURATION command.

Figure 3-1 shows the location of the DIP switch component on the 24-Port Module.

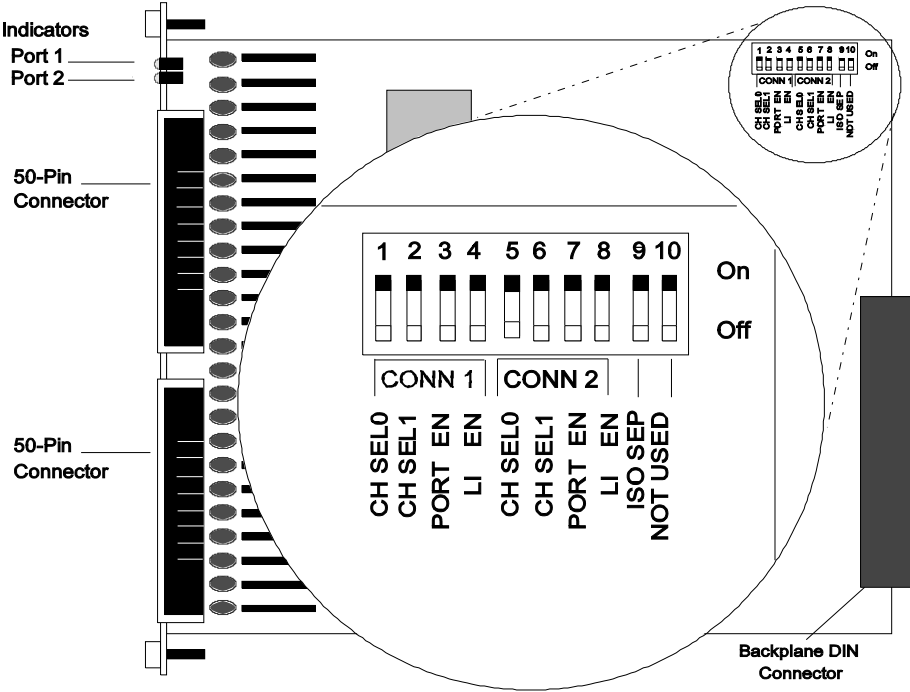

Figure 3-1. Model 5124M-TPCL and Model 5124M-TP DIP Switch Location

DIP Switch Description

DIP switches are labeled 1 through 10 (refer to Figure 3-1). DIP switches 1 through 4 enable features for connector 1 (CONN 1). DIP switches 5 through 8 enable features for connector 2 (CONN 2). DIP switch 9 isolates all ports (both connectors) from the backplane, or 12 ports on either connector. Modules or ports set to the same network communicate with each other.

Note: The DIP switch label on the module circuit board refers to the backplane connection as “channel” (CH). This is the “network” setting.

Tables 3-2 and 3-3 describe DIP switch settings. For a complete definition of each DIP switch function, refer to the section Configuring the Module later in this chapter.

Table 3-2. DIP Switch Settings

DIP Switch	Label	Function	Factory Default	DIP Switch Setting	
				Off	On
1 2	CH SELO CHSEL1	Select Connector 1 Network	See Table 3-3.		
3	PORT EN	Enable/Disable Connector 1 Ports	Enable	Disable	Enable
4	LI EN	Enable/Disable Connector 1 Link Integrity	Enable	Disable	Enable
5 6	CH SEL 0 CH SEL 1	Select Connector 2 Network	See Table 3-3.		
7	PORT EN	Enable/Disable Connector 2 Ports	Enable	Disable	Enable
8	LI EN	Enable/Disable Connector 2 Link Integrity	Enable	Disable	Enable
9	ISO SEP	Isolate One/Both Connectors	One	Both	One
10	Not Used	None			

The channel select switch settings (switches 1 and 2 for connector 1, and switches 5 and 6 for connector 2) let you select a channel for each connector. To reconfigure the module to a different channel, refer to the information in Table 3-3.

Table 3-3. Channel (Network) Select DIP Switch Settings

DIP Switch Setting (CONN 1)		DIP Switch Setting (CONN 2)		Network Selection
Switch 1	Switch 2	Switch 5	Switch 6	
On	On	On	On	1 (default)
Off	On	Off	On	2
On	Off	On	Off	3
Off	Off	Off	Off	Isolated (connector operates independent of the three backplane networks)

Installing the Module

You do not need to power down the ONline System Concentrator to install the 24-Port Module. You can insert the module while the concentrator is operating (this is called a *hot swap*).

To install a 24-Port Module:

1. Depending on whether or not you have a management module installed in the hub, follow one of the steps below:
 - ❑ If network management is not available, set the DIP switches on the board (if different than the default values). Refer to Table 3-2 and Table 3-3 for an explanation of the DIP switch settings.
 - ❑ If a network management module is installed in your concentrator:
 - If your management module is not EMM Version v4.3 or later (for Model Number 5124M-TP) or EMM Version v3.2 or later (for Model Number 5124M-TPCL), it does not support the particular 24-Port Module. Enter the SET DEVICE DIP_CONFIGURATION command to configure the 24-Port Module from DIP switch settings.
 - If your management module is at the appropriate software level, go to step 2 and complete the installation, then configure the 24-Port Module using the commands described in the Configuring the Module section.
2. For Model Number 5124M-TPCL, locate one open slot in the concentrator. Remove the blank panel on the concentrator to expose a slot for the module.

For Model Number 5124M-TP, locate two adjacent open slots in the concentrator. If there are no adjacent open slots, remove two adjacent blank panels on the concentrator to expose the slots you need to install the module.

3. Insert the module into the board guides at the top and bottom of the selected slot and slide the board into the concentrator. Make sure the connector is well-seated into the backplane of the concentrator.

Figure 3-2 shows the installation of a 24-Port Module.

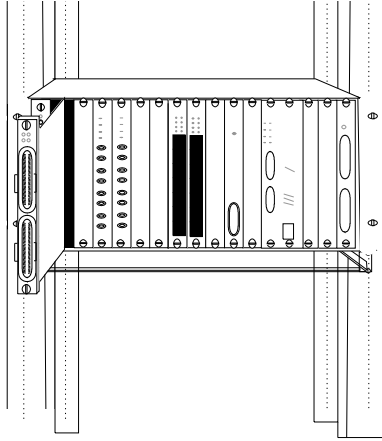
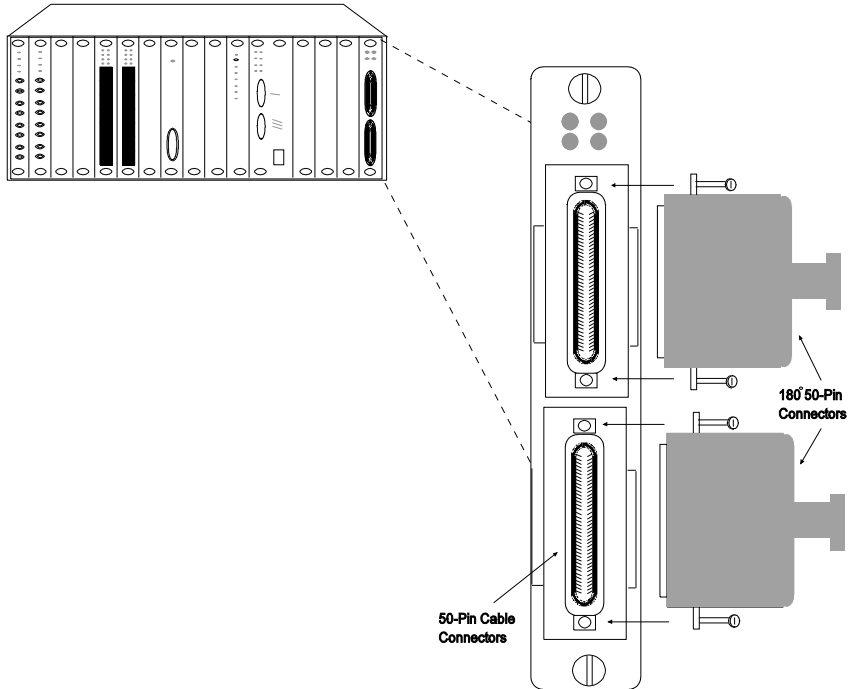

Figure 3-2. Installing a 24-Port Module (Model Number 5124M-TPCL)

4. Fasten the spring-loaded screws on the front of the 24-Port Module faceplate to the concentrator with your fingers (do not overtighten).
5. For the 5124M-TPCL model only, use the small screws included in the shipping carton and attach 180° 50-pin cable connectors to the 50-pin connectors on the front of the module (refer to Figure 3-3) .

Note: If you are using 90° connectors, refer to the special instructions provided in the section Using 90° Cable Connectors.

6. If you have installed Model Number 5124M-TPCL, attach and secure cable connectors to module connectors as shown in Figure 3-3.



**Figure 3-3. 24-Port Module Cable Connection
(Model Number 5124M-TPCL)**

7. Attach the other ends of the cables to any of the following:
 - A 10BASE-T transceiver
 - A patch panel
 - A 10BASE-T adapter card

Using 90° Cable Connectors

3Com recommends that you use 180° connectors with the 5124M-TPCL model. Because of the proximity of the two connectors, you must follow the special steps described below if you decide to use 90° (right-angle) connectors.

This section describes:

- ❑ Installing the Cable Tie-Wrap Kit
- ❑ Securing 90° Cables to the Module

Installing the Cable Tie-Wrap Kit

A cable tie-wrap kit is included with the 24-Port Module. If you use a cable connector other than a 180° cable connector (for example, a 90° cable connector), you must secure the cable to the module connector using the tie-wrap kit.

The tie-wrap kit contains:

- ❑ Kit card containing kit part number
- ❑ 1 Phillips-head screw
- ❑ 1 Tie-wrap bracket
- ❑ 3 Tie-wraps

To install the tie-wrap kit:

1. Remove the hex nut from the bottom of the connector located on the module faceplate.
2. Using the Phillips-head screw provided in the tie-wrap kit, attach the tie-wrap bracket to the module (Figure 3-4).

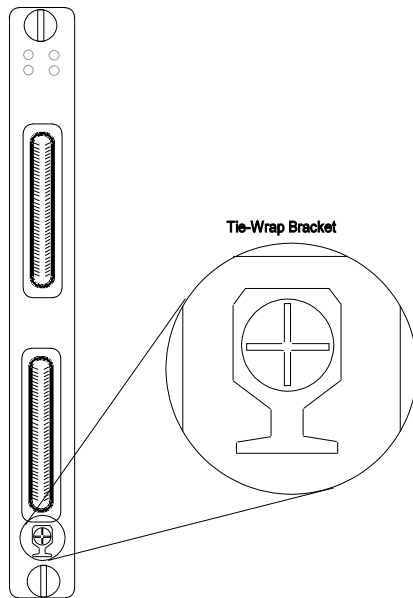

Figure 3-4. Attaching the Tie-Wrap Bracket to the Module

3. Insert the tie-wrap through the opening on the tie-wrap bracket.

Securing 90° Cables to the Module

To secure 90° cables to the 24-Port Module connectors:

1. Remove the small cable-fastening screws from the shipping carton.
2. Remove the long screws (if present) from the 50-pin cables.
3. Attach a 50-pin cable connector to one of the 50-pin connectors on the front of the module (see Figure 3-5).

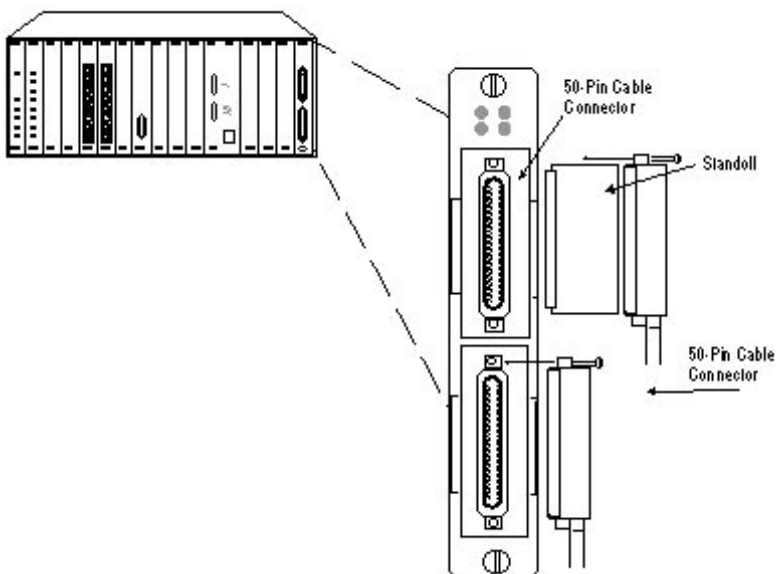

**Figure 3-5. Attaching Cables With 90° Connectors
(Model Number 5124M-TPCL)**

Note: Due to the proximity of the top and bottom 50-pin connectors, you must install a standoff if you intend to use a right-angle connector on the top connection. Contact your 3Com representative if you need more information.

4. Replace the small screw in the top screw hole of the 50-pin cable connectors to secure the cables to the module connectors as shown in Figure 3-5.

Note: Do not overtighten the top screw on either connector. Over tightening the top screw can cause the bottom part of the connector to lift and disconnect the lower pins on the cable from the lower pins on the module connector.

5. Wrap the tie-wrap around the cable connector to secure the cable connector to the module connector (see Figure 3-6). Do not fasten the tie-wrap around the module ejectors.

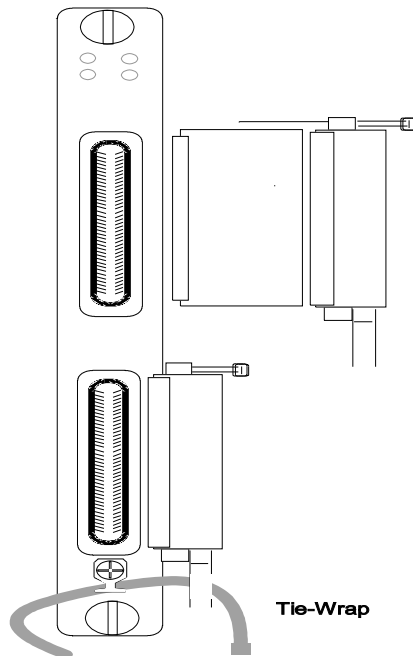

Figure 3-6. Attaching Cables With 90° Connectors

6. Attach the other ends of the cables to any of the following:
 - A 10BASE-T transceiver
 - A patch panel
 - A 10BASE-T adapter card

Configuration in a Managed Environment

With an EMM already installed, all DIP switch settings on the 24-Port Module are ignored. For this reason, 3Com recommends that you use network management commands instead of DIP switches to configure the module.

Note: Do not use a slave management module to manage (for example, configure or get statistics for) a 24-Port Module.

Note: To fully support Model Number 5124M-TPCL, you must have EMM Version v3.2 or later. To fully support Model Number 5124M-TP, you must have EMM Version v4.30 or later.

The following sections describe important module configuration issues and settings you can configure for both models of the 24-Port Module:

- If Management is Not Available
- Before Configuring the Module
- Enabling Ports
- Enabling Port Redundancy
- Enabling Link Integrity
- Selecting a Network

- ❑ Enabling Remote Diagnostics Mode
- ❑ Setting the Autopartition Threshold Value

For additional information on any network management command described in this section, refer to the appropriate *ONline Management Module Installation and Operation Guide*.

If Management is Not Available

When you first install the 24-Port Module in an unmanaged concentrator, configure the 24-Port Module using the DIP switches as described in the section Setting the DIP Switches. For additional information on all network management features, refer to:

- ❑ The appropriate *ONline Management Module Installation and Operation Guide*, or the *ONcore Distributed Management Module User's Guide*
- ❑ The *ONline Management Commands Guide* or the *ONcore Distributed Management Module Commands Guide*

Note: The 24-Port Module, Model Number 5124M-TP, is a 2-slot module that has a double-wide faceplate but only one circuit board. The slot number of the circuit board determines the slot number of an installed 5124M-TP module.

Before Configuring the Module

When you first install the 24-Port Module in a managed concentrator:

1. The network (channel) defaults to isolated mode and all ports are automatically disabled so unapproved stations cannot be added. Therefore, you must use management commands to:
 - Enable ports you want to use
 - Assign enabled ports to backplane networks
2. All other module settings retain DIP switch default values.

Enabling Ports

You can enable or disable each of the ports on the 24-Port Module. When a port is enabled, it can transmit to and receive data from the network (channel) that the module or connector (bank) is assigned to.

To enable a port, use the following network management command:

```
SET PORT {slot.port} MODE {enable}  
        {slot.all}      {disable}
```

Enabling Port Redundancy

Network management lets you set redundancy between ports. When you set two ports redundant to each other, the secondary port takes over if the primary port fails.

To set redundancy between ports, use the following management command:

```
SET PORT {slot.port} MODE {redundant} {slot.port}  
                        {non-redundant}
```

Refer to Chapter 2 for an example of port redundancy.

Enabling Link Integrity

Use the following guidelines to determine whether to enable or disable Link Integrity:

- ❑ Enable Link Integrity for all ports on the 24-Port Module for networks that comply with the 10BASE-T standard.
- ❑ Disable Link Integrity *only* when connecting to older equipment that does not comply with the 10BASE-T standard.

The Link Integrity setting at both ends of a connection must be *either* enabled or disabled. If Link Integrity settings are not configured to the same setting, the 24-Port Module with Link Integrity enabled reports a Link Integrity error.

The Link Status LED for each connector (bank) will be on solid if the Link Integrity is valid for ports which are both enabled and have Link Integrity *enabled*. If all enabled ports have Link Integrity testing *disabled* the LED is also on solid. In all other cases the LED will blink in approximately 1-second intervals.

Note: In an unmanaged concentrator, you can only enable or disable Link Integrity for each *connector* on the module.

To enable Link Integrity for a port:

```
SET PORT {slot.port} LINK_INTEGRITY {enable}  
        {slot.all}                 {disable}
```

Selecting a Network

The ONline Ethernet 24-Port Module provides bank-level configuration flexibility.

To assign all 24 ports on the module to one of three backplane networks, use the following management command:

```
SET MODULE {slot} NETWORK {ethernet_1}
                           {ethernet_2}
                           {ethernet_3}
                           {isolated}
```

To assign a specific connector (bank of 12 ports) to a network, use the following management command:

```
SET MODULE {slot} CONNECTOR_{1}_NETWORK {ethernet_1}
                                           {2}      {ethernet_2}
                                           {ethernet_3}
                                           {isolated_1}
                                           {isolated_2}
```

Note: Assigning one connector to ISOLATED_1 and the other connector to ISOLATED_2 creates two isolated 12-port subnetworks. Assigning *both* connectors to the same isolated network creates a single 24-port isolated network.

Enabling Remote Diagnostics Mode

When used with a 3Com Fault-Tolerant 10BASE-T Transceiver, remote diagnostics mode allows the 24-Port Module to detect certain unusual failure conditions (including disruption of single wires in the twisted pairs).

Refer to the *Fault-Tolerant 10BASE-T Transceiver Installation Guide* for more information on this feature.

To enable remote diagnostics mode for a specific port, use the following management command:

```
SET PORT {slot.port} MODE {remote_diagnostics} {slot.port}
                          {non_remote_diagnostics}
```

Setting the Autopartition Threshold Value

To set the maximum number of data collisions an installed management module allows on a port before it partitions the port, use the following management command:

```
SET MODULE {slot} AUTOPARTITION_THRESHOLD {31_coll}
                                           {63_coll}
                                           {127_coll}
                                           {255_coll}
```

You can set the autopartition threshold value to one of the following:

- 31
- 63 (default value)
- 127
- 255

The proper setting for most network environments is 63 (the default). The 10BASE-T specification suggests a minimum autopartition threshold value of 31, but 31 collisions may cause ports to partition more frequently than necessary.

Note: Autopartition values 127 and 255 are suggested only for debugging purposes, and are not recommended for use in live networks.

Saving Module Configurations

After you make configuration changes to a module and ports, you must issue the `SAVE MODULE_PORT` command to save the new settings.

Showing Module Configurations

You can display status information about the 24-Port Module using the following network management commands:

- ❑ `SHOW MODULE`
- ❑ `SHOW PORT`

This section describes these commands. Screen output examples are also provided.

For more information, refer to the *ONline Ethernet Management Module Installation and Operation Guide*.

Note: When the command argument `NO_VERBOSE` is an option, you do not have to type `NO_VERBOSE`, `NO_VERBOSE` is the default.

Show Module

To display information for a module in a specific slot, use the following management command:

```
SHOW MODULE {slot} {no_verbose}
           {verbose}
```

To display *basic* information about a 24-Port Module installed in slot 3, specify the NO_VERBOSE command argument, as shown below:

```
ONline> show module 3 [ENTER]

Slot   Module      Version   Network      General Information
03     5124M-TPCL  001      ETHERNET_2   Port (s) are down
```

Note: The NO_VERBOSE command argument is the default (you do not have to enter it at the prompt).

To display *detailed* information about an installed 24-Port Module, specify the verbose command argument, as shown below:

```
ONline> show module 3 verbose [ENTER]

Slot   Module      Version   Network      General Information
03     5124M-TPCL  001      ETHERNET_2   Port (s) are down
```

```
5124M-TPCL:    ONline Ethernet 24-PORT 10BASE-T Module
```

```
Auto-Partition Threshold           : 255 COLLISIONS
Module Per Port Counters            : CONNECTOR 1
Network for Connector 01            : ETHERNET_2
Network for Connector 02            : ETHERNET_2
Dip Network Setting for Connector 01 : ETHERNET_1
Dip Network Setting for Connector 02 : ISOLATED_1
```

Show Port

To display information for a specific port, use the following management command:

```
SHOW PORT {slot.port} {no_verbose}
          {slot.all}  {verbose}
```

To display *basic* information for a specific port, specify the NO_VERBOSE command argument. To display *basic* information for all ports on the 24-Port Module, specify the ALL command argument.

Note: The NO_VERBOSE command argument is the default (you do not have to enter it at the prompt).

In the following example, SHOW PORT ALL displays basic information for all ports on the 24-Port Module installed in slot 5:

```
ONline> show port 5.all [ENTER]
Port Display for Module 5124M-TPCL :
Port      Mode      Status      Network      General Information
-----
05.01     DISABLED    OKAY        ISOLATED
05.02     ENABLED     OKAY        ISOLATED
05.03     ENABLED     OKAY        ISOLATED
05.04     DISABLED    OKAY        ISOLATED
.
.
.
```

To display *detailed* information for all ports on the 24-Port Module, specify the VERBOSE command argument. In the following example, SHOW PORT ALL VERBOSE displays detailed information for all ports on the 24-Port Module installed in slot 17 (only the output for ports 1 and 2 is shown):

```
ONline> show port 17.all verbose [ENTER]
Port Display for Module 5124M-TPCL :
Port      Mode      Status      Network      General Information
-----
17.01    DISABLED    OKAY        ISOLATED
Port Connector:                                TELCO
Mode Dip Setting:                             ENABLED
Link Integrity:                               ENABLED
Link Integrity Dip Setting:                   ENABLED
17.02    DISABLED    OKAY        ISOLATED
Port Connector:                                TELCO
Mode Dip Setting:                             ENABLED
Link Integrity:                               ENABLED
Link Integrity Dip Setting:                   ENABLED
.
.
.
```

Gathering Network Statistics

When you assign all ports on the 24-Port Module to the same network, an installed management module can simultaneously monitor all ports on one connector *individually* as it monitors the ports on the other connector *collectively*.

For example, you can use an installed EMM or Distributed Management Module (DMM) to simultaneously:

- ❑ Monitor ports 1 through 12 individually
- ❑ Sum up statistics for ports 13 through 24 at a single “logical port” (port 13)

Gathering statistics for individual ports on one connector enables network management to provide a detailed statistical view of each port on that connector. Collective statistics gathering for all ports on the *other* connector ensures you have at least a high-level statistical view of ports on that connector.

An ONline management command lets you switch to monitor the other connector. The following section describes the SET MODULE command.

Selecting the Per-Port Counters Connector

When you select a connector, network management monitors the other connector collectively, reporting statistics for all 12 ports as a single “port.”

To select which 12-port connector you want network management to gather counter statistics for:

```
SET MODULE {slot} PER_PORT_COUNTERS_CONNECTOR {1}
                                                {2}
```

If you ask for information on a port that is not being monitored individually, network management displays summary statistics and instructions for getting more information on the selected port.

Note: The MONITOR PORT and SHOW COUNTER PORT commands will function normally for the connector you have selected.

Note: Changing which connector you are monitoring clears all statistics counters. Use the CLEAR COUNTERS command to erase extraneous statistics gathered during the switchover from one connector to the other connector.

Monitoring the Front Panel

The LEDs on the front panel of the 24-Port Module allow you to monitor the status of 12 ports on each connector. The 24-Port Module has an Activity LED and a Status LED for each connector.

Figure 3-7 shows the location of the LEDs on Model Number 5124M-TPCL.

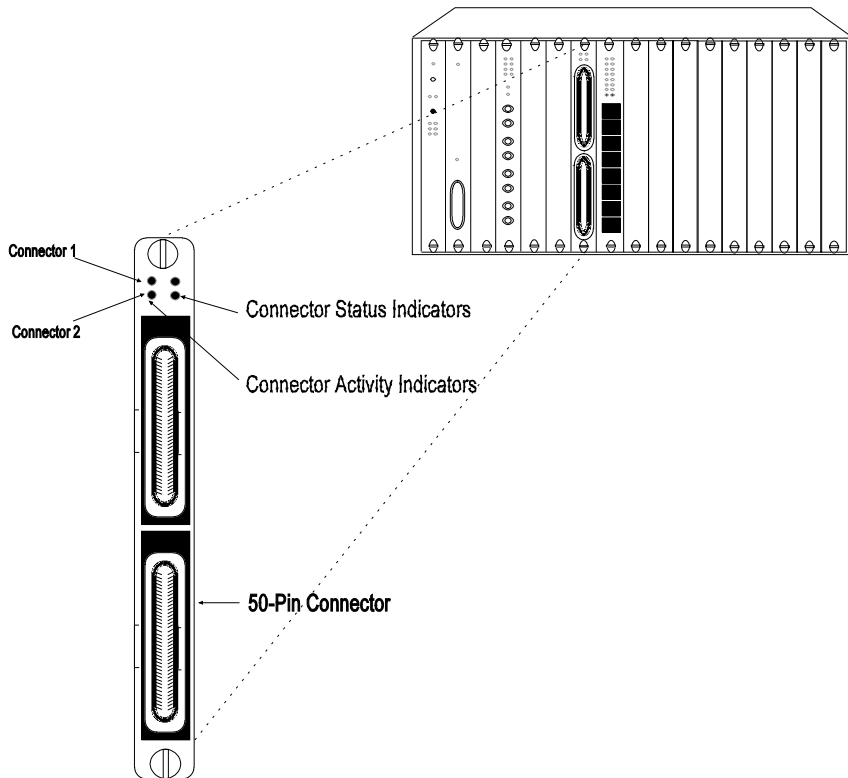

Figure 3-7. 24-Port Module Faceplate and ONline System Concentrator (Model Number 5124M-TPCL)

Figure 3-8 shows the location of the LEDs on Model Number 5124M-TP.

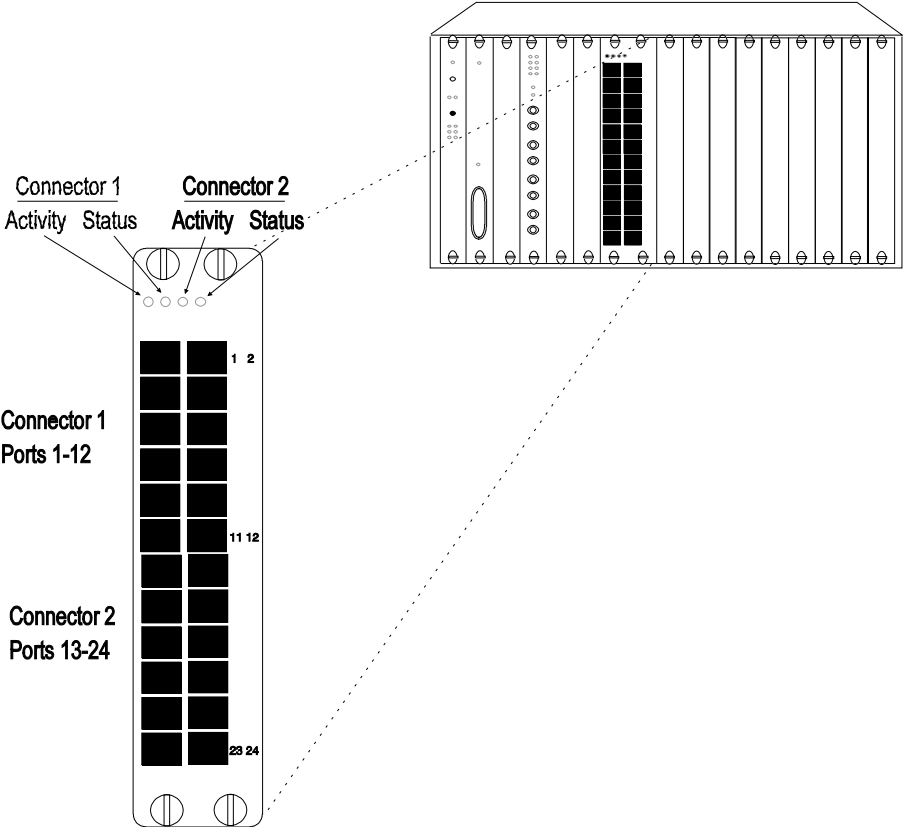

Figure 3-8. 24-Port Module Faceplate and ONline System Concentrator (Model Number 5124M-TP)

Table 3-4 describes the LEDs for Model Numbers 5124M-TPCL and 5124M-TP.

Table 3-4. 24-Port Module LED Interpretations

LED Name	Color	State	Indicates
Activity (Ports 1 to 12) (Ports 13 to 24)	Yellow	Off	No packets are received on the ports on this connector.
		On	Constant activity on this connector.
		Blinking	Normal activity on this connector.
Status (Ports 1 to 12) (Ports 13 to 24)	Green	On	Connector enabled and links OK or Link Integrity disabled.
		1 blink	Link failure on one or more ports.
		2 blinks	One or more ports partitioned.
		Off	Connector disabled.

Verifying LED and Network Assignments

Once you install the 24-Port Module, verify module operation using the front panel of the ONline Controller Module.

Using the LED Check Button

The ONline Controller Module is equipped with an LED check button on the front panel. Use the LED check button to:

- Verify LED operation
- Verify network (channel) assignment

The LED check button:

- Causes all LEDs in all modules in the concentrator to light
- Causes each installed module to identify the network to which it is assigned

When you press the LED check button, the Controller Module initiates a test of all modules in the concentrator.

- All LEDs should respond by lighting continuously for approximately 5 seconds.
- Any LED that does not light is defective.

After 5 seconds elapse, the diagnostic continues with a network (channel) check of all installed modules.

- Port Status LEDs on each installed module should blink the number of times corresponding to the network to which that module (or connector) is assigned.

- ❑ If the module is in isolated mode, the Port Status LEDs on that module (or connector) do not light.
- ❑ Activity LEDs remain on during the network check sequence.

The *network check sequence* repeats at least three times, and each check sequence lasts for approximately 30 seconds.

Table 3-5 explains the network check codes.

Table 3-5. Network Check Codes

LED State	Network Configuration
1 Blink	Connector is configured for network 1
2 Blinks	Connector is configured for network 2
3 Blinks	Connector is configured for network 3
Off	Connector is isolated from backplane networks

4 *Troubleshooting*

This chapter describes fault conditions and troubleshooting procedures for the ONline Ethernet 24-Port Modules, Model Numbers 5124M-TPCL and 5124M-TP.

This chapter contains the following sections:

- ❑ Troubleshooting Using the Port Status LEDs
- ❑ Troubleshooting Using the Port Activity LEDs
- ❑ Technical Assistance

Troubleshooting Using the Port Status and Port Activity LEDs

In certain situations, the Port Status and Port Activity LEDs may not light. This section describes troubleshooting using the:

- ❑ Port Status LEDs
- ❑ Port Activity LEDs

Troubleshooting Using the Port Status LEDs

A blinking Port Status indicator signals a problem with a port or a link connected to a port. Once a port detects a problem, you can further analyze the problem by counting the number of blinks. Table 4-1 provides troubleshooting suggestions for each of the blinking sequences.

Note: LEDs provide accurate information only when unused ports are disabled.

Table 4-1. Troubleshooting Using the Port Status LEDs

LED State	Indication	Possible Cause	Corrective Action
1 Blink	Link Failure	Cable not connected.	Connect cable.
		Cable defective.	Check cables with cable tester. Repair or replace cables.

Table 4-1. Troubleshooting Using the Port Status LEDs (Continued)

LED State	Indication	Possible Cause	Corrective Action
1 Blink (continued)	Link Failure (continued)	Link Integrity mismatch.	Make sure that both ends of the connection have the same Link Integrity setting.
2 Blinks	Port Partitioned	Faulty cable.	Check cable with cable tester. Repair or replace cable.
		Network overloaded.	Reassign users to another network to balance the load.
Off	Ports Disabled	Ports disabled.	Enable ports.
		24-Port Module not powered up.	Check the Controller Module Power LEDs.
		Broken LED.	Press the LED test button on the Controller Module.
		Bad 24-Port Module.	Replace module.

Troubleshooting Using the Port Activity LEDs

Under some conditions a Port Activity LED may not light. Use the troubleshooting suggestions in Table 4-2 to help determine why this has occurred and to isolate the source of the problem.

Table 4-2. Troubleshooting Using the Port Activity LEDs

LED State	Possible Cause	Corrective Action
Off	There is no traffic received from the segments (normal).	None.
	Hub power is off.	Check the Controller Module Power LEDs.
	The Activity LED has burned out.	Press the LED test button on the Controller Module.
	A 24-Port Module port is faulty.	Connect the cable to a different port.
	The module connection to the backplane is bad.	Re-insert the 24-Port Module. If this fails to correct the problem, try another concentrator slot.
	The 24-Port Module is faulty.	Try a different 24-Port Module.

Technical Assistance

Refer to Appendix B for instructions on contacting Technical Support for your product.

A *Specifications*

This appendix lists specifications for the ONline Ethernet 24-Port Module (Model Numbers 5124M-TPCL and 5124M-TP).

This appendix contains the following sections:

- ❑ General Specifications
- ❑ Power Specifications
- ❑ Environmental Specifications
- ❑ Mechanical Specifications
- ❑ Twisted Pair Cable and Connector Specifications

General Specifications

Table A-1 defines general specifications for the 24-Port Module.

Table A-1. 24-Port Module General Specifications

Specification	Value
Model Number	5124M-TP, 5124M-TPCL
Ports Per Module	24
Data Rate	10 Mbps (million bits per second)
Data Modulation	Differential Manchester
External Connectors	Model Number 5124M-TP: 2 Double Stack RJ-45 Connectors (12 ports per connector) Model Number 5124M-TPCL: 2 Telco 50-pin Connectors (12 ports per connector)
Recommended Cable Types	Supports UTP, STP, and 120 ohm Cabling Systems
Maximum Number of Stations	1024
Backplane Interface	96-pin edge connector of the ONline System Concentrator or ONcore Switching Hub
Installation Attachment	2 thumbscrews on the mounting bracket

Table A-1. 24-Port Module General Specifications (Continued)

Specification	Value
ONline Requirements	ONline Fault-Tolerant Controller Module (Model Numbers 5000M-RCTL, 5000M-RCLS) A Fault-Tolerant Controller Module is <i>not</i> required if you have a 6-Slot ONline System Concentrator with Integrated Controller (Model Numbers 5006C-HC, 5006C-HC-FT). A 325 watt power supply and the corresponding 325 watt Power Switching Board is required for the 17-Slot ONline System Concentrator

Power Specifications

Table A-2 lists power specifications for the 24-Port Module.

Table A-2. 24-Port Module Power Specifications

Power Specifications	Values
Backplane Interface	Two 96-pin edge connectors, compatible with the ONline System Concentrator and ONcore Switching Hub
Power Requirements	2.0 Amps @ 5 V
Power Consumption	10 watts
Fuse	4.0 Amps Fast Blow

Table A-3 lists fuse specifications for the 24-Port Module.

Table A-3. 24-Port Module Fuse Specifications

Fuse Specifications for 24-Port Module
.5 Amp for 12 V FAILSAFE
4 Amp for 5 V

Environmental Specifications

Table A-4 lists environmental specifications for the 24-Port Module.

Table A-4. 24-Port Module Environmental Specifications

Environmental Specifications	Values
Operating Temperature	0° to 50° C (32° to 122° F)
Storage Temperature	-30° to 65° C (-22° to 149° F)
Humidity	5% to 95%, non-condensing
BTUs/hour	30

Mechanical Specifications

Table A-5 lists mechanical specifications for the 24-Port Module.

Table A-5. 24-Port Module Mechanical Specifications

Mechanical Specifications	5124M-TPCL Values	5124M-TP Values
Dimensions	2.54 cm W x 27.31 cm L x 21.6 cm H (1.0" x 10.75" x 8.5")	5.08 cm W x 27.31 cm L x 21.6 cm H (2.0" x 10.75" x 8.5")
Weight	0.57 kg (1.25 lb.)	0.68 kg (1.5 lb.)

Twisted Pair Cable and Connector Specifications

You can use many types of cables and connectors to link a 24-Port 10BASE-T Module to your network. These cables and connectors are explained in the following sections. Use this information to ensure that the cables and connecting hardware meet requirements. For proper operation, use only approved cables when you install all equipment.

This section describes:

- Twisted Pair Cable Specifications
- Twisted Pair Connector Specifications
- RJ-45 Connector Pinouts
- 50-Pin Connector Pinouts
- Connecting Twisted Pair Cables

Twisted Pair Cable Specifications

The cables that are supported must meet the following specifications:

- ❑ 22, 24, or 26 gauge twisted pair cable
- ❑ 80 to 150 ohm impedance
- ❑ Minimum of 2 pairs

A *pair* is usually a solid color wire twisted with a striped wire of the same color.

Table A-6 lists the specifications for IBM cable types 1, 2, 6, and 9. These cable types are IEEE 802.5 compliant and are ETL (ETL Testing Laboratories) verified.

Table A-6. IBM Twisted Pair Cable Specifications

IBM Type	No. of Pairs	AWG	Shielding	Nominal Impedance
1 (non-plenum)	2	22 (solid bare copper)	Data pairs individually foil shielded plus 65% tinned copper braid	150 ohms
2 (non-plenum)	6 (data 2) (voice 4)	22 (solid bare copper)	Data pairs individually foil shielded plus 65% tinned copper braid. Voice pairs non-shielded*	Data 150 ohms Voice 105 ohms
6 (non-plenum)	2	26 (7x34 bare copper)	Overall foil shielded pairs plus 65% tinned copper braid	150 ohms
9 (plenum)	2	26 (7x34 bare copper)	Individually foil shielded plus 65% tinned copper braid	150 ohms

Note that the non-plenum type 1, 2, and 6 cables are insulated with polyethylene. The plenum type 9 cable is insulated with polyvinylchloride.

*Voice pairs in the IBM Type 2 cable cannot be used for Token Ring data transmission.

Twisted Pair Connector Specifications

The IEEE 802.3 10BASE-T standard for RJ-45 pinouts must be used, as described below. 10BASE-T uses only 2 of 4 pairs of wire: pins 1 & 2 and pins 3 & 6. If the pairs are not configured this way, the connection will not work properly.

Level 3 or higher cable should have the following pin pairings:

- Pair 1 is pins 4 and 5 (not used)
- Pair 2 is pins 3 and 6
- Pair 3 is pins 1 and 2
- Pair 4 is pins 7 and 8 (not used)

Refer to Figure A-1 for an example of the recommended TIA-568A standard pinouts for this connector and cable.

RJ-45 Connector Pinouts

Figure A-1 shows RJ-45 connector pin assignments for the 24-Port Module, Model Number 5124M-TP. This model uses MDI-X (crossed-over) wiring and only uses:

- Pins 1 and 2 (station transmit) - 5124M-TP receive
- Pins 3 and 6 (station receive) - 5124M-TP transmit

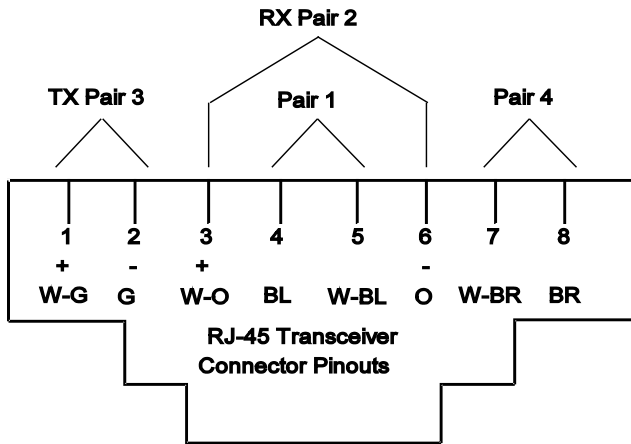

Figure A-1. 24-Port Module RJ-45 Connector Pinouts

50-Pin Connector Pinouts

Figure A-2 provides examples of a 50-pin cable (male) connector and a 50-pin (female) connector on the 24-Port Module.

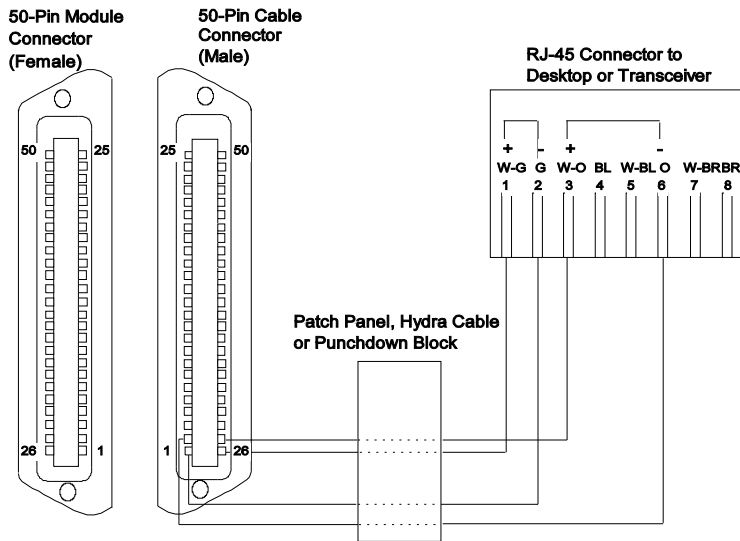

Figure A-2. 50-Pin Male and Female Connectors

Table A-7 (next page) lists the receive and transmit pairs, pinouts, and port assignments for a 50-pin cable.

Table A-7. 50-Pin Cable Pinouts and Port Assignments

Hub Port#	Hub Pin#	Hub Function/ Polarity	Transceiver Function /Polarity	Hub Port#	Hub Pin#	Hub Function/ Polarity	Transceiver Function /Polarity
Port 1	26	RX, +	TX, + (1)	Port 7	38	RX, +	TX, + (1)
Port 1	1	RX, -	TX, - (2)	Port 7	13	RX, -	TX, - (2)
Port 1	27	TX, +	RX, + (3)	Port 7	39	TX, +	RX, + (3)
Port 1	2	TX, -	RX, - (6)	Port 7	14	TX, -	RX, - (6)
Port 2	28	RX, +	TX, + (1)	Port 8	40	RX, +	TX, + (1)
Port 2	3	RX, -	TX, - (2)	Port 8	15	RX, -	TX, - (2)
Port 2	29	TX, +	RX, + (3)	Port 8	41	TX, +	RX, + (3)
Port 2	4	TX, -	RX, - (6)	Port 8	16	TX, -	RX, - (6)
Port 3	30	RX, +	TX, + (1)	Port 9	42	RX, +	TX, + (1)
Port 3	5	RX, -	TX, - (2)	Port 9	17	RX, -	TX, - (2)
Port 3	31	TX, +	RX, + (3)	Port 9	43	TX, +	RX, + (3)
Port 3	6	TX, -	RX, - (6)	Port 9	18	TX, -	RX, - (6)
Port 4	32	RX, +	TX, + (1)	Port 10	44	RX, +	TX, + (1)
Port 4	7	RX, -	TX, - (2)	Port 10	19	RX, -	TX, - (2)
Port 4	33	TX, +	RX, + (3)	Port 10	45	TX, +	RX, + (3)
Port 4	8	TX, -	RX, - (6)	Port 10	20	TX, -	RX, - (6)

Table A-7. 50-Pin Cable Pinouts and Port Assignments (Continued)

Hub Port#	Hub Pin#	Hub Function/ Polarity	Transceiver Function /Polarity	Hub Port#	Hub Pin#	Hub Function /Polarity	Transceiver Function /Polarity
Port 5	34	RX, +	TX, + (1)	Port 11	46	RX, +	TX, + (1)
Port 5	9	RX, -	TX, - (2)	Port 11	21	RX, -	TX, - (2)
Port 5	35	TX, +	RX, + (3)	Port 11	47	TX, +	RX, + (3)
Port 5	10	TX, -	RX, - (6)	Port 11	22	TX, -	RX, - (6)
Port 6	36	RX, +	TX, + (1)	Port 12	48	RX, +	TX, + (1)
Port 6	11	RX, -	TX, - (2)	Port 12	23	RX, -	TX, - (2)
Port 6	37	TX, +	RX, + (3)	Port 12	49	TX, +	RX, + (3)
Port 6	12	TX, -	RX, - (6)	Port 12	24	TX, -	RX, - (6)
					50	Not Used	Not Used
					25	Not Used	Not Used

Connecting Twisted Pair Cables

Follow these steps to connect twisted pair cables:

1. Connect cables at the active concentrator location.
2. Connect transceivers.

Refer to the *ONline System Concentrator Installation and Operation Guide* for more information about the ONline System Concentrator connections.

B *Technical Support*

3Com provides easy access to technical support information through a variety of services. This appendix describes the following services:

- On-line Technical Support
- Support from Your Network Supplier
- Support from 3Com
- Returning Products for Repair
- Accessing the 3Com MIB
- 3Com Technical Publications

On-line Technical Support

3Com offers worldwide product support through the following on-line systems:

- Email Technical Service
- World Wide Web Site

Email Technical Support

You can contact the Integrated Systems Division (formerly Chipcom) on the Internet for technical support using the e-mail address techsupp@chipcom.com.

World Wide Web Site

You can access the latest networking information on the 3Com World Wide Web site by entering our URL into your Internet browser:

<http://www.3Com.com/>

This service features news and information about 3Com products, customer service and support, the 3Com latest news releases, selected articles from 3TECH™, the 3Com award-winning technical journal, and more.

You can contact the Integrated Systems Division on the World Wide Web by entering our URL into your Internet browser:

<http://www.chipcom.com/>

There are links between both WWW pages to view information from all 3Com divisions.

Support from Your Network Supplier

If additional assistance is required, contact your network supplier. Many suppliers are authorized 3Com service partners who are qualified to provide a variety of services, including network planning, installation, hardware maintenance, application training, and support services.

When you contact your network supplier for assistance, have the following information ready:

- ❑ Diagnostic error messages
- ❑ A list of system hardware and software, including revision levels
- ❑ Details about recent configuration changes, if applicable

If you are unable to contact your network supplier, see the following section on how to contact 3Com.

Support from 3Com

If you are unable to receive support from your network supplier, technical support contracts are available from 3Com.

For direct access to customer service for Integrated Systems Division products in:

- ❑ U.S.A. and Canada - call (800) 724-2447
- ❑ Asia Pacific - call (508) 787-5151
- ❑ Europe - refer to the table below
- ❑ For European countries not listed, call 31 30 60 299 00

Country	Telephone Number	Country	Telephone Number
Belgium	0800 71429	Netherlands	06 0227788
Denmark	800 17309	Norway	800 11376
Finland	0800 113153	Spain	900 983125
France	05 917959	Sweden	020 795482
Germany	0130 821502	U.K.	0800 966197
Ireland	1 800 553117	U.S.	800 876-3266
Italy	1678 79489		

For access to customer service for all 3Com products, call (800) 876-3266.

You can also contact the Integrated Systems Division (ISD) on the Internet by using the e-mail address techsupp@chipcom.com.

Returning Products for Repair

A product sent directly to 3Com for repair must first be assigned a Return Materials Authorization (RMA) number. A product sent to 3Com without an RMA number will be returned to the sender unopened, at the sender's expense.

To obtain an RMA number for Integrated Systems Division products (formerly Chipcom), use the following numbers.

Country	Telephone Number	Fax Number
U.S. and Canada	(800) 724-2447	(508) 787-3400
Europe	(44) (1442) 275860	No Fax
Asia Pacific	(508) 787-5296	(508) 787-3400

Accessing the 3Com MIB

The 3Com Management Information Base (MIB) for the Integrated Systems Division describes commands that enable you to manage 3Com SNMP-based products. The MIB is available over the Internet on an anonymous FTP server. Updates to these MIBs are released as new 3Com products are introduced.

To access Internet versions:

1. FTP to `ftp.chipcom.com` (151.104.9.65).
2. Enter the login name `anonymous`.

3. Enter your full Internet e-mail address as the password (for example, `jdoe@company.com`).
4. Change to the `mib` or `schema` directory using the `cd /pub/mibs` or `cd /pub/mibs/schemas` command.
5. To view the 3Com MIB, OID, or schema entries, enter the `dir` command.
 - ❑ To pause the display, press [CTRL-S].
 - ❑ To continue the display, press [CTRL-Q].
6. Copy the MIB, OID, or schema files to your current directory using the appropriate command (for example, `get chipcom.mib`).
7. To exit the FTP session, invoke the `quit` command.

3Com Technical Publications

If you have comments or questions on 3Com Integrated Systems Division Technical Publications documents, please contact the Technical Publications group by FAX (508) 229-1551.

Index

Numerics

- 10BASE-FB Links
 - Determine Maximum Distance, 2-7
- 10BASE-FB Module
 - Fiber Backbone, UTP-to-the-Desk, 2-10
 - Port Redundancy, 2-15
 - Serial Configuration, 2-9
 - Star Configuration, 2-8
- 24-Port Module
 - Activity LEDs, 4-4
 - Features, 1-2
 - Hot Swap Capability, 1-2
 - Installing, 3-10
 - Port Status LEDs, 4-2
 - Procedures for Handling, 3-2
 - Theory of Operation, 1-4
 - Unpacking Procedures, 3-4
- 24-Port Module LEDs
 - Interpreting, 3-31
- 3Com Bulletin Board Service (3ComBBS), B-3
- 50-Pin Cable
 - Pinouts and Port Assignments, A-10
- 50-Pin Connector, A-8

A

- Activity LEDs
 - Troubleshooting With, 4-4
- Attenuation, 2-7
- Audience of Manual, xiii

B

- Backbone Cabling, 2-7
 - Serial Wiring, 2-9
 - Star Wiring, 2-8
- bulletin board service, B-3

C

- Cabling
 - Connectors, A-7
 - Redundant Links, 2-16, 2-17
 - Twisted Pair Backbone, 2-12
- Configuration Rules
 - General, 2-3, 2-5
 - Twisted Pair Backbone, 2-12
- Crossover Mode, 1-3

D

- DIP Switches
 - Location, 3-5
- Dip Switches, 3-5
 - Setting, 3-4

E

- Electro-Static Discharge
 - Precautionary Procedures, 3-2
- Ethernet
 - Four-Repeater Rule, 2-12
- Ethernet Distance Limitations, 2-2

F

- Fault-Tolerant Controller Module, A-3
- FCC notice, ii
- Features, 1-1
- Fiber Link Distances, 2-5
- Fiber Module Configurations, 2-10
- Front Panel
 - Monitoring, 3-29
- Front Panel Indicators
 - Activity LEDs, 3-29, 3-31
 - Status Indicators, 3-29
 - Status LEDs, 3-31

G

- General Specifications, A-5

I

- Installation
 - 180 Connector, 3-11
 - 90 Connectors, 3-15
 - Hot Swap Capabilities, 3-10
 - Installing The Module, 3-11
 - Quick Installation Chart, 3-2
- Installing the 24-Port Module, 3-10
- Installing the Module, 3-2

L

- LAN Product Equivalent Distances, 2-6
- LED and Network Verification, 3-32
- Link Integrity
 - Configuring Using Network Management, 3-20
 - Description, 3-20

M

- MIB, B-4
- Module Configurations

- Saving, 3-23
- Showing, 3-23

N

- Network
 - Unshielded Twisted Pair, 2-13
- Network Check Codes, 3-33
- Network Selection
 - Per Connector, 3-21
- network supplier support, B-2

O

- ONline Network Management Module, 3-19
- ONline System Concentrator
 - Hot Swap Capabilities, 3-10
- on-line technical services, B-1

P

- Patch Panels, 2-14
- Port Redundancy, 3-19
 - Switchover Conditions, 2-17
- Ports
 - Configuring Using Network Management, 3-19

R

- Redundancy, 2-17
- Redundant Links, 2-16
- returning products for repair, B-4

S

- Serial Configuration, 2-9
- Showing Module Configurations, 3-23
- SNMP Commands, B-4
- Specifications
 - Environmental, A-4
 - Fuses, A-3

- Power, A-3
- Star Configuration, 2-8
- Star Topology, 2-3
- Status LEDs
 - Troubleshooting Using, 4-2

T

- technical support, B-1
- Troubleshooting
 - Port Activity LEDs, 4-4
 - Using Port Status LEDs, 4-2
- Twisted Pair
 - Cables, A-6, A-12
 - Connectors, A-7
- Twisted Pair Cables
 - Connecting, A-12
- Twisted Pair Configuration
 - Redundant Links, 2-16

U

- Unpacking Procedures, 3-4
- Unshielded Twisted Pair, 2-12

V

- VDE compliance, ii

